

MUSCATINE POWER AND WATER WATER SERVICE RULES

APPROVED BY THE BOARD OF TRUSTEES: JUNE 28, 2022

WELCOME TO MUSCATINE POWER AND WATER

We designed this handbook to help you understand Muscatine Power and Water's processes and procedures in order to provide you the best service possible. It covers topics ranging from service installation to meter reading to billing. Keeping you well informed is important to us, so we have compiled our Service Rules in this concise and easy-to-use format. If you have any questions about the Service Rules or Muscatine Power and Water, please feel free to call us at 563-263-2631 or stop at our Business Office at 3205 Cedar Street in Muscatine.

Annual water quality information can be obtained through the Annual Consumer Confidence Report or via www.mpw.org.

Remember, exceptional service is our goal and what keeps Muscatine Power and Water - Your Reliable Neighbor.

This document may also be found on our web site at www.mpw.org.

TABLE OF CONTENTS

1. STATEMENT OF OPERATION

Preliminary Statement.....	1-1
Definitions	1-1

2. SERVICE

Type of Service	2-1
Extent of Service (Availability).....	2-1
Temporary Water Supply.....	2-2
New Construction	2-2
Industrial Customers.....	2-2
Service Classification.....	2-4
Residential	2-4
Commercial.....	2-4
Industrial I	2-4
Industrial II	2-4
Water Main Taps.....	2-4
Responsibilities.....	2-4
Water Service Connections	2-5
Water Tap Fees	2-5
Water Service Lines	2-6
Property Owner Responsibilities	2-6
Corporation Stops and Tapping Valves.....	2-6
Adjacent Property	2-6
Two-Inch or Greater Service Lines.....	2-6
One to Two Inch Service Lines.....	2-7
Additional Water Requirements.....	2-7
Service Line Breaks or Leaks.....	2-7
Frozen Lines	2-7
Backflow Prevention	2-7
Building Demolition.....	2-8
Inadequate Water Service	2-8
Curb Stop Risers or Valve Boxes.....	2-8
No Private Wells	2-8
Meters	2-8
Meters Two Inches and Smaller	2-8
Additional Meters.....	2-8
Meter Size.....	2-8
Regular Periodic Meter Testing	2-9
Meter Testing Upon Customer Request.....	2-9
Meter Damage	2-9

Remote Reading Water Meters	2-9
Meter Installations	2-9
Labor Charges	2-9
Contractor Responsibilities	2-9
Meter Location	2-10
Bypass Plumbing – Two Inches or Less	2-10
Bypass Plumbing – Three Inches and Larger	2-10
Installing More than One Meter in a Building	2-10
Optional Outdoor Aesthetic Meter Enclosures	2-10
Electrical Grounding	2-10
Meter Enclosures	2-10
Access to Meters	2-11
Tampering and Unauthorized Consumption	2-11
Tampering	2-11
Unauthorized Consumption	2-11
Jumpers	2-11
Water Conservation and Emergencies	2-11
Limitation of Utility Liability	2-11
Right to Deny Service	2-12

3. WATER MAIN EXTENSIONS, IMPROVEMENTS, & HYDRANTS

General	3-1
Water Main Extensions	3-1
Main Extensions	3-1
Special Assessment	3-2
Hydrants	3-2
Installation	3-2
Relocation	3-2
Removal	3-2
Installation Outside City Limits	3-2
Hydrant Usage	3-2
Prohibited Usage of Fire Hydrants	3-3

4. CUSTOMER RELATIONS

Application for Service	4-1
Deposits	4-1
Credit Criteria for Initial Service Deposits	4-1
Initial Service Deposits	4-2
Credit Criteria for New or Additional Deposits	4-2
Deposit Calculation Criteria	4-2
Receipt for Deposit	4-2
Interest on Deposits	4-3

Deposit Refund	4-3
Unclaimed Deposits and Overpayments	4-3
Billing Information	4-3
Billing Form	4-3
Bill Payment Terms	4-4
Partial Payments	4-4
Returned Checks and ACH Rejects	4-4
Budget Billing	4-4
Payment Agreements – Residential Customers	4-5
Types and Terms of Payment Agreements	4-5
Adjustment of Bills after Issuance (Meter Error)	4-6
Disconnections, Denials, and Reconnections	4-7
Customer Initiated (Voluntary)	4-7
Utility Initiated (Involuntary)	4-7
Utility Initiated (Involuntary – Due to Nonpayment)	4-8
Disconnection	4-8
Reconnection	4-9
Abnormal Water Consumption	4-9
Insufficient Reasons for Denying Service	4-9
Charges for Services	4-9
Charged Services	4-9
Non-charged Services	4-9
Underground Facilities Locating	4-10
Customer Communications	4-10
Utility Customer Representative	4-10
Telephone Procedure	4-10
Complaint Procedure	4-10
Customer Obligations	4-11
Use of the Utility’s Facilities by Customers and Others	4-11
Customer Liability for Damages or Alterations	4-11
Customer Equipment	4-11
Access to Customer Premises	4-12

5. WATER EXHIBITS

STATEMENT OF OPERATION

PRELIMINARY STATEMENT

Muscatine Power and Water's (MPW) utility services are provided only in accordance with these Service Rules and applicable Utility policies and procedures. These rules are intended to ensure safe installation of facilities, long life of infrastructure, and that all customers are treated fairly. By accepting Utility services, customers agree to be bound by these Service Rules and applicable Utility policies and procedures.

The Board of Water, Electric, and Communications Trustees of the City of Muscatine, Iowa has approved and published the Service Rules. These Service Rules are subject to change from time to time to ensure safe and efficient service and to comply with city, state, and federal statute and applicable administrative law.

All work shall be in accordance with the Standard Specifications for Water Supply Distribution System Improvements as approved by and on file with the Iowa Department of Natural Resources.

These Service Rules are intended to govern the overall operation of the Water Utility. Where a rule cannot be reasonably applied to a specific situation, the Governing Body reserves the right to decide on a resolution to the issue.

The Utility's records are maintained at the MPW Business Office located at 3205 Cedar Street, Muscatine, Iowa. Address all written correspondence to Muscatine Power and Water, 3205 Cedar Street, Muscatine, Iowa, 52761.

DEFINITIONS

The following words and phrases shall have the following meanings, as used in these Service Rules:

Applicant

Means a person, partnership, association, firm, public or private corporation, governmental agency, or legal entity applying to the Utility for service provided for in these Service Rules.

AWWA

Means American Water Works Association.

Complaint

Means a statement or question by anyone, whether a Utility customer or not, alleging a wrong, grievance, injury, dissatisfaction, illegal action or procedure, dangerous condition or action, or Utility obligation.

Contiguous Locations

Means those locations where one customer has more than one building on the same property or on adjacent property separated only by a public right-of-way.

Contract

Means any claim, account, or demand against, or in agreement with, the Utility, express or implied.

Contractor

Means any person, firm, or corporation performing work for a customer.

Customer

Means any person, firm, association, or corporation, any agency of the federal, state, or local government, or legal entity responsible by law for payment for the water service from the Utility.

Delinquent or Delinquency

Means an account for which a service bill or service payment agreement has not been paid in full on or before the last date for timely payment.

Governing Body

Means the Board of Water, Electric, and Communications Trustees of the City of Muscatine, Iowa.

IDNR

Means Iowa Department of Natural Resources.

Meter

Means, unless otherwise qualified, a utility-approved device that measures and registers the quantity of water used.

Premises

Means a tract of land, building, or part of a building or facility to which services are provided.

Service Rules

Means these rules as adopted by the Board of Water, Electric, and Communications Trustees of the City of Muscatine, Iowa.

Tampering

Means any unauthorized connection or usage of service as defined in the appropriate theft of utility services policy or procedures.

Timely Payment

Means a payment on a customer's account made on or before the due date shown on a current bill for service, or in conformance with an agreement between the customer and the Utility for a series of partial payments to settle a delinquent account, as the date which determines application of a late payment charge to the current bill or future collection efforts.

Utility

Means Muscatine Power and Water (MPW).

Water Service Line

Means the water line carrying water from the Utility main to the customer's meter.

SERVICE

TYPE OF SERVICE

Extent of Service (Availability)

MPW supplies customers with water from water mains through meters owned by the Utility or as otherwise noted. The property owner installs, owns, and maintains the water service line from the main to the meter in accordance with these Service Rules. Additional plumbing regulations of the City of Muscatine not addressed by these rules may apply.

Service will only be provided to parcels adjacent to or parallel to appropriately sized water distribution mains.

Please refer to the *No Private Wells* section for information regarding MPW service and private wells.

There will be only one address with one meter served by a service line except as listed below, or otherwise noted in these Service Rules.

For water main extensions outside the city limits, please refer to the *Board Policy Manual*.

Multiple Occupancy Buildings

There are 2 options for multiple occupancy buildings:

- Each Unit can be considered a separate customer and metered and billed separately.
- Property owner can assume responsibility for payment of water consumed by the tenants in apartments or offices under one roof. These units are billed under one meter.

Water cannot be resold as restricted by the Iowa Administrative Code.

Combined Bill

Any firm or corporation under one roof, or a group of buildings at one contiguous location, separated only by public property, may be furnished services through one or several meters. At MPW's discretion, customers served by more than one meter may receive a combined bill.

Mobile Home Parks

Each mobile home park is considered a single customer and shall be billed accordingly. A water service contract is required.

The Utility cautions that submetering in mobile home parks creates numerous compliance issues. Mobile home park operators should consult with Iowa DNR on their responsibilities with operating a private water system.

Subdivisions

New subdivisions served by MPW will conform to MPW construction specifications. Services will be metered and billed individually.

Existing subdivisions outside of the city limits will be evaluated for connection to the MPW system, considering the following:

- If the customer base is residential only, then the subdivision may connect to an existing MPW water main with certain conditions. The service valve is the demarcation between MPW and the private subdivision system. The subdivision is responsible for any maintenance and repair of their private water distribution system. Each residential service will be metered and billed individually by MPW. Each resident will be considered an individual customer of MPW. In such a case, MPW does not make assurances of fire flow capacity.

- If the customer base for the subdivision includes a commercial or industrial customer, the connection request will be evaluated by MPW staff, and staff will make a recommendation to the Board for consideration.

In either case, a Water Service Agreement will be required. Also, if a subdivision's water system has a line break or leak, the subdivision shall engage a bonded and licensed plumber within 48 hours after notification by Utility. The break or leak must be repaired or replaced within the timeframe required by the Utility. MPW may discontinue service until repairs are made. All MPW-provided services will be billed to the subdivision at the current rate. Customer is responsible for MPW's costs to address any unsafe conditions or damages related to a water system break or leak, such as cost of lost water, after hours call outs, associated equipment charges, etc.

Irrigation Systems (Commercial & Industrial)

A second meter that is parallel to the domestic meter will be installed to measure water flow to irrigation systems or other systems in which the water does not flow into the City of Muscatine's wastewater system.

Fire Protection System

A water meter shall be installed in the detector loop of a backflow preventer on a fire protection system. See the *Backflow Prevention* section for more information on backflow preventers on fire lines.

Temporary Water Supply

MPW may authorize a temporary water supply, if deemed necessary by the Utility. Construction water cannot be used for irrigation, dust suppression, or settling dirt around foundations.

New Construction

When a building is under construction and a water service line has been installed with a main valve, water may be consumed from the water service line for construction purposes. A minimum bill shall be issued based on the service size. Water shall not be consumed from the building's plumbing system unless a water service contract has been filed, approved, and a meter has been installed. Construction water shall not be used for irrigation, dust suppression, or settling dirt around foundations.

Hydrant connections may be provided on a case-by-case basis. The Utility reserves the right to select the hydrant to be used. See the *Hydrants* section for more information.

Industrial Customers

All customers with a demand of at least 50,000 cubic feet ("Industrial Customers") are subject to the following additional terms and conditions.

Character of Service

It is MPW's intent to provide water to the point of delivery at a pressure between 40 psig and 100 psig. However, this pressure range cannot be guaranteed, but in no event shall water pressure drop below 20 psig except during interruptions of service.

The Utility will not be held liable to provide peak day requirements for an Industrial Customer in any year which exceeds the peak day use of the previous year, unless 12 months' prior written notice of the intent to increase such use is given to the Utility to permit construction of added facilities where needed.

The Utility uses certain treatment chemicals in the water system. The Utility is not liable for any damage caused to any raw material, manufactured product, or process equipment resulting from the use of water that has been treated in the concentrations normally acceptable for potable water as defined by the applicable Drinking Water Standards.

Industrial Customers must eliminate any cross-connections between an Industrial Customer's own water system (such as a private well system) and the Utility's water distribution system to prevent cross-contamination of the Utility's system. Such cross-contamination may pose a risk to public health and safety, therefore failure to maintain the separation of any Industrial Customer's water system from the Utility's system may be grounds for disconnection.

Industrial Customers must comply with all applicable portions of the City of Muscatine Code, Iowa Code, Iowa Administrative Code, and federal regulation or law.

Access and Relocation

Industrial Customers must permit duly authorized MPW representatives to enter the premises at all reasonable times in order to carry out Utility-related tasks and services. Should an Industrial Customer request the Utility to relocate any part of its water distribution system or equipment or both, the Industrial Customer will reimburse the Utility for the actual cost of such relocation.

Rates

Rates for Industrial Customers shall be established by the Utility on a periodic basis.

No Resale

Industrial Customers shall not sell or otherwise dispose of any Utility supplied water to any other party except to a corporation or joint venture in which the Industrial Customer directly owns or controls an interest.

Metering

Industrial Customers must supply adequate housing for the meter with sufficient space adjacent to the meter to permit reading, maintenance, and testing. The housing must be heated by the Industrial Customer if required to prevent freezing. Industrial Customer must also provide adequate drainage up to 200 gallons per minute to facilitate meter testing.

In the event that more than one service from Utility's main is required by an Industrial Customer, the cost of all meters including installation except for first meter shall be borne by the Industrial Customer. The Industrial Customer is responsible for the cost of relocating any meter for their convenience after initial installation.

Industrial Customers shall reimburse the Utility for the cost of any special meter tests made at the Industrial Customer's request that discloses that the meters are recording accurately.

Industrial Customers' metering is also subject to backflow prevention requirements. See *Backflow Prevention* section for additional requirements.

Fire Hydrants and Water Used in Fire Protection.

The Utility's obligation as to fire hydrants for supplying water for fire protection is satisfied by hydrants located adjacent to but outside the Industrial Customer's premises. To supplement these facilities, Industrial Customers may install, at their expense, such additional hydrants and/or sprinkler systems necessary or desirable on their own premises. All such hydrants and/or sprinkler systems on an Industrial Customer's premises shall be supplied from the downstream side of the Industrial Customer's metering equipment. See *Backflow Prevention* section for additional requirements.

Maintenance Scheduling

When possible, the Utility will contact an Industrial Customer in advance to schedule regular maintenance of Utility's facilities which may affect supply of water to the Industrial Customer. Not all activities that could interfere with the provision of water services can be anticipated and interruptions may occur from time to time.

The Utility's Service Rules also apply to Industrial Customers. In case of a contradiction between a provision of the remainder of the Service Rules and a term in this section, the more specific term shall govern.

SERVICE CLASSIFICATION

Service classification shall be based on the type of service supplied and on similarities in customer demand characteristics. Service classifications shall be defined as part of the rate schedules adopted by the Governing Body. In addition, the Utility reserves the right to supply Industrial I and Industrial II service in accordance with the provisions of a written contract. As nearly as practicable, rate schedules adopted by MPW shall reflect relative differences in the costs of providing various quantities of service to each customer class. The Utility reserves the right to assess additional charges to special classes of customers or customers in defined areas where the circumstances require additions or improvements to the water distribution system

Residential

Residential water service is based on a facilities charge and base rate per cubic foot of water used.

Commercial

Commercial water service is based on a facilities charge and tiered rate per cubic foot of water used. It is for customers with a monthly billing demand of less than 50,000 cubic feet.

Industrial I

Industrial I water service applies to customers with a monthly billing demand of 50,000 cubic feet to 500,000 cubic feet. A contract is required for this class of service.

Industrial II

Industrial II water service applies to customers with a monthly billing demand greater than 500,000 cubic feet. A contract is required for this class of service.

WATER MAIN TAPS

Responsibilities**MPW Responsibilities**

MPW is responsible for:

- Making all taps to the mains for water service connections.
- Installing the corporation stop.

Customer Responsibilities

The customer is responsible for:

- Supplying the tapping valve and sleeve (if required).
- Installing the water service line from the corporation stop or tapping valve and sleeve to meter.

Contractor Responsibilities

The customer’s plumbing contractor is responsible for:

- Excavating the water main as per MPW’s safety standards and OSHA rules.

Water Service Connections

The customer or plumber will be charged for the cost of the water main connection. MPW will provide an estimated cost for the water main connection upon request.

Water service connections larger than 2” require a tapping valve and sleeve, to be furnished by the customer. The tapping valve and sleeve must meet MPW’s material specifications. The customer is required to perform a pressure test of the tapping valve and sleeve with a MPW representative present to verify the test before the tap is made to the main.

All service connections and taps will need executed service contracts before connecting to the system. MPW must receive advance notice of at least 2 working days before services can be provided for connections or inspections.

The Utility reserves the right to inspect all piping and plumbing connected to its distribution system to maintain the safety of the water supply.

Service connections will not be provided if additional sources are in use (i.e., private well).

Water Tap Fees

The flat fee for water taps is currently set as follows:

Size	Fee
1”	\$400
1 ½”	\$500
2”	\$600
4”	\$650
6” and larger	\$750

These rates will be reviewed each January and revised as needed. MPW may require a pre-payment for this work.

WATER SERVICE LINES

Property Owner Responsibilities

The drawing below shows various parts of the residential water service and the responsible parties for each. The property owner is responsible for purchasing, installing, and maintaining all water service lines in a serviceable condition so meters can be installed or removed as needed. Information on the Utility Loan Program and Service Line Warranty Program is available on www.mpw.org.

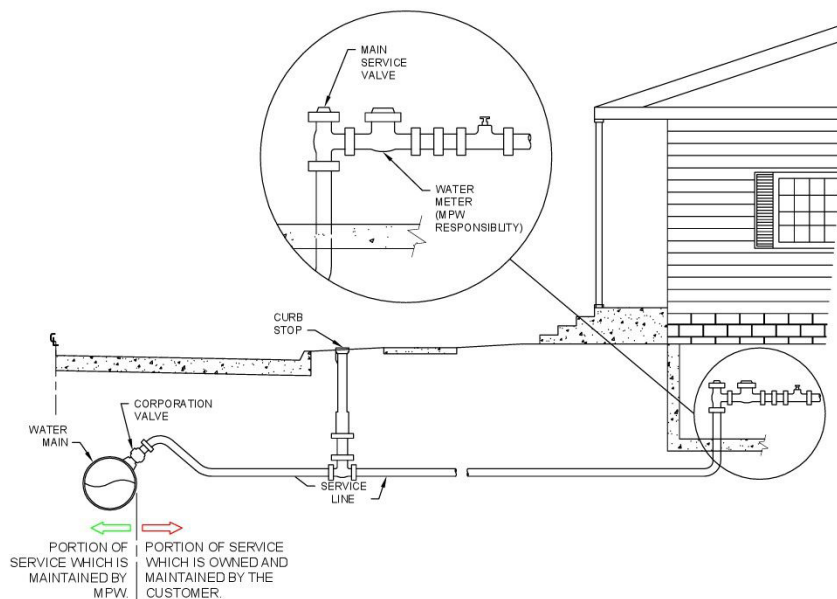

Corporation Stops and Tapping Valves

A water service line consists of a corporation stop or tapping valve and sleeve installed in the Utility's water main. A water service line is extended from the water main to the customer's property line, and a curb stop and riser or valve box is installed. The remainder of the service line terminates at the water service line's main valve. Corporation stops are considered part of the customer's service line. (See Exhibit 1)

Adjacent Property

Water service lines shall not cross adjacent private property unless MPW has reviewed and approved the plans.

Two-Inch or Greater Service Lines

New 2" water service lines must be flushed and bacteria tested before the meter will be set. Water lines greater than 2" must be flushed, chlorinated, and bacteria tested before the meter will be set. These activities are the responsibility of the customer. Lines shall be inspected at the customer's expense.

One to Two Inch Service Lines

The minimum service size shall be 1 inch. All new or replaced water service lines must be the same size as the corporation stop. The service shall be Type “K” copper pipe with properly sized curb shut-off and valve installed on the water service line. (See Exhibit 1) HDPE with tracer wire may be allowed from the curb stop to the house with prior approval of the Utility. If the main is HDPE, copper is *not* required between the main and the curb stop.

Additional Water Requirements

If additional water is required, a meter with a larger capacity may be installed, up to the point where meter capacity equals service capacity. If additional capacity is required in the existing building or in an additional building, the customer shall install a new water service line from the Utility main.

Service Line Breaks or Leaks

If a water service line breaks or leaks, the property owner shall engage a bonded and licensed plumber within 48 hours after notification by the Utility. The line must be repaired or replaced within the timeframe required by the Utility. MPW may discontinue service until repairs are made. All MPW-provided services will be billed to the property owner at the current rate. Customer is responsible for MPW's costs to address any unsafe conditions or damages related to a water service line leak, such as cost of lost water, icing, damage to roadways and sidewalks, after hours call outs, associated equipment charges, etc.

If it is determined during repairs or construction that a customer's water service line is constructed of lead or galvanized steel, the Utility will require the customer to replace the entire line with approved materials.

Frozen Lines

The customer is responsible for thawing and/or repair of frozen water service lines.

Backflow Prevention

MPW's *Backflow Prevention Policy* governs backflow prevention, and requires, among other items, the following:

- A reduced pressure zone backflow preventer be installed on all commercial and industrial water services, including fire lines.
- A detector check type of backflow preventer on all fire lines.
- Installation of backflow preventers immediately downstream from the Utility's water meter or, in the case of a fire line, where the service enters the building. Backflow preventers cannot be placed in pits.
- Backflow prevention for isolation in residential applications for in-ground irrigation systems and swimming pools, boilers, or any other device that could allow polluted or contaminated fluids to enter the building's water system. The City of Muscatine may have additional rules pertaining to backflow prevention for isolation of equipment.
- Testing of all backflow preventers annually by a certified backflow prevention test technician and the test results sent to MPW.
- Compliance with AWWA C510-07 and C511-07.

Building Demolition

When a building served or previously served by the Utility is demolished, it is the property owner's responsibility to disconnect all water services to the property by removing the curb stop risers or valve boxes and to disconnect the water service lines at the main. This shall be done before power is disconnected from the property. The only exception is if the property owner enters into a written agreement with MPW identifying that the current service line to the curb stop is approved material and declaring that the water service line will be utilized within one year. The Utility shall require a deposit or bond as assurance the property owner will comply with the agreement.

Inadequate Water Service

When a building's water service line becomes inadequate and a new water service line is installed, it is the property owner's responsibility to remove the inadequate water service line, curb stop riser, or valve box, and disconnect the water service line at the main when the new water service line becomes active.

Curb Stop Risers or Valve Boxes

All curb stop risers or valve boxes installed on the customer's water service line must be flush with the surface of the ground, street, or sidewalk and shall be maintained in that condition to avoid a hazard. All curb stop risers must be the telescoping type. Upon notification by the Utility, the customer must adjust the height of water service line valve box or curb stop riser to flush with the existing surface within 14 days. (See Exhibit 1)

No Private Wells

MPW water customers are prohibited from operating private wells on properties served by the Water Utility, without prior approval of the Utility. Where a private well is allowed to exist on a property with MPW water service, the private well is only to be used for irrigation purposes. Plumbing modifications are required to eliminate any cross connections and backflow prevention is required on all (including residential) MPW Water Utility services in accordance with the *Backflow Prevention Policy*.

METERS

Meters Two Inches and Smaller

MPW owns and furnishes all water meters 2" and smaller.

Meters will be selected, furnished, owned, installed, and removed by the Utility.

Additional Meters

The Utility will supply the first water meter at a location. If additional water meters are required by a customer at one contiguous location, it is the customer's responsibility to pay for the additional water meter(s), including installation, and to reimburse the Utility for all maintenance and replacement costs, except for periodic testing. All water meters purchased and installed by the customer shall comply with Utility specifications.

Meter Size

MPW determines the size of the meter(s). Residential meters must be 5/8" by 3/4" without irrigation and 3/4" with irrigation. A residential customer requesting a larger size meter must complete the Water Customer Data Sheet, and MPW will size the meter accordingly.

For commercial or industrial meters 3/4" or greater, sizing will be based on information provided by the customer or their representative on the Water Customer Data Sheet.

Regular Periodic Meter Testing

MPW tests all water meters and associated equipment for accuracy before placing them into service and periodically thereafter in accordance with the American Water Works Association (AWWA) Standards as adopted by the Utility.

Meter Testing Upon Customer Request

In addition to regular periodic meter testing, the customer may request a meter accuracy test of the meter servicing their account, providing that such test shall not be made more frequently than once in an 18-month period. The customer or their representative may be present when the meter is tested and the results shall be reported to the customer within 10 days. If the test finds the meter accurate within the limits accepted by the Utility according to its meter inspection and testing program, the customer may be billed for the cost of the test or \$30.00, whichever is less.

Meter Damage

The customer is responsible for all damage to, or loss of, Utility property located on the customer's property unless the damage or loss is due to the negligence of the Utility or by any act or omission on the part of the Utility or its authorized representative. The customer must protect meters from freezing or accidental damage and may not permit persons other than agents of the Utility to remove, inspect, or repair meters.

Remote Reading Water Meters

All buildings with outside electric metering must have a remote reading device installed on the water meter by the Utility at no cost to the customer.

Upon request from a customer, the Utility will install a remote reading device on the water meter where the electric meter is located inside the premises for a fee equal to the cost of installation.

METER INSTALLATIONS

Labor Charges

When the Utility receives a request to set a water meter, and the Utility's service technician finds that the plumbing does not meet the rules contained herein, the customer or plumbing contractor may be charged for the labor and truck time for making the unnecessary trip to the site.

Contractor Responsibilities

Water meters shall be installed as close to the service entrance as possible. The contractor shall install Utility-furnished meter couplings or flanges, contractor-furnished lever, ball, or gate valve on each side of the meter.

Installations shall be in an accessible place with:

- A 4' clear frontal approach and clear access to the meter, with a minimum of 7' of head room, and
- A clear working area of 1' from either side of the meter centerline, a minimum of 6" from an adjacent wall to the nearest edge of the meter's main body and no closer than 6" or more than 3' from the floor.

On water services that require a backflow prevention device, the contractor shall install and test the backflow prevention device immediately after the Utility sets the water meter. The contractor must provide a test report within 30 days.

Meter Location

Meters shall be installed near the service entrance but shall not be installed in the vertical position, near temporary partitions, in air or elevator shafts, in close proximity to belts, motors, fans, or machinery, in any place subject to excessive vibrations, extreme temperature, or in places dangerous to MPW Meter Readers and service technician.

Bypass Plumbing – Two Inches or Less

In cases where water meter installations are 2" or less in size and where the customer determines it is critical that water flow not be interrupted for meter maintenance, it shall be the customer's responsibility to install bypass plumbing around the meter with appropriate valving approved by the Utility. Bypass valving shall be sealed by the Utility to ensure proper use.

Bypass Plumbing – Three Inches and Larger

A test outlet and bypass plumbing is required for all meter installations 3" and larger. Bypass and test outlet plumbing shall be in accordance with the Utility's large water meter installation specifications. The meter testing outlet shall be extended to outside of the vault or building in which the meter is housed. The terminated end shall be equipped with a 2½" fire hose adapter.

Installing More than One Meter in a Building

Meters installed in building housing more than one customer must be clearly identified and marked as to which customer is being served by each meter. Meters shall be located in one central location, unless otherwise approved by the Utility.

Optional Outdoor Aesthetic Meter Enclosures

Aesthetic meter installation enclosures are not recommended due to moisture problems. If MPW deems it necessary and approves the installation, it is the customer's responsibility to construct the enclosure as per the following guidelines, which are in addition to and in no way preclude or lessen any other requirements stated in the *Meter Installations* section. The enclosure shall be constructed with ventilation and shall be removed by the customer during meter maintenance.

Electrical Grounding

Grounding of a building's electric distribution system to the metal water piping system is required according to the City of Muscatine's Electric Code. It shall be a requirement to loop a copper wire to bypass the water meter. The looped copper wire shall conform to the National Electric Code, according to electric service size, and be bonded to the metal water pipe with a minimum distance of 3" upstream from the main service valve and 3" downstream from the back water valve. The jumper serves as a safety function for the customer, plumbers, and MPW service technician. In most cases, the water meter will not be set unless the jumper is in place.

Meter Enclosures

Meter enclosures outside and below ground level are not recommended due to sanitation and weather conditions. If MPW deems the meter enclosure necessary and approves the plans, it is the customer's responsibility to furnish all plumbing fixtures and construction materials and to construct and maintain the

enclosure, according to the Utility's specifications, including protection from freezing and provisions for adequate drainage. (See Exhibits 2 through 9)

Access to Meters

MPW authorized representatives must have access to meters at all reasonable hours for the purpose of inspecting, testing, removal or setting, and reading meters. If access is not possible due to an obstruction on the customer's property surrounding the meter, it will be the customer's responsibility to provide access in a timely manner.

TAMPERING AND UNAUTHORIZED CONSUMPTION

Tampering

Visible seals will be placed on all meters, water service line meter valves, and bypass valves for the purpose of security. Breaking of these seals or tampering with meters, their associated equipment, or interconnecting piping is prohibited to maintain the safety and integrity of the system.

Evidence of tampering will result in an investigation based upon the Utility's theft of utility services policies and procedures. The parties involved will be subject to costs and penalties as described in the policies and procedures and may be prosecuted under the laws of the State of Iowa.

Unauthorized Consumption

If a customer is found consuming water in such a way that the usage is not registered through an MPW-provided meter, service may be disconnected without notice. The incident will be investigated under the appropriate theft of utility services policies or procedure, and the responsible parties will be subject to the associated fees for the investigation. The customer will also be required to install, at their expense, the necessary plumbing to direct all usage through the MPW-provided meter. The parties involved will be subject to costs and penalties as described in the policies and procedures and may be prosecuted under the laws of the State of Iowa.

Jumpers

During construction of a new building, customers and plumbing contractors may install a jumper in place of the meter only for testing for leaks in the building's plumbing if an application for service is on file and approved by the Utility. Immediately after testing, the jumper shall be removed and shall at no time be left in overnight. Whenever jumpers are found, the service will be turned over for investigation under the appropriate theft of utility services policies and procedures, and the responsible parties will be subject to the associated fees for the investigation. When the plumbing is ready for active service, the customer or plumber shall notify the Utility so that the meter can be set.

WATER CONSERVATION AND EMERGENCIES

In order to ensure the general welfare of the people of Muscatine, water resources should be used in such a way as to prevent waste and unreasonable use. Should an emergency arise and water availability becomes limited, water shall be curtailed in accordance with the Utility's *Water Curtailment Policy*.

LIMITATION OF UTILITY LIABILITY

MPW cannot guarantee a utility service will be free from interruptions or fluctuations in service. The Utility will not be liable for any injury, loss, or damage resulting from interruption, shortage or insufficiency of service, or irregularities of service (e.g., flushing, discolored water, pressure changes, etc.) unless caused

by willful acts or gross negligence on the part of the Utility. In no event shall MPW be liable for consequential or punitive damages.

TO THE MAXIMUM EXTENT PERMITTED BY APPLICABLE LAW, MPW DISCLAIMS ALL WARRANTIES, EITHER EXPRESS OR IMPLIED, INCLUDING, BUT NOT LIMITED TO, IMPLIED WARRANTIES OF MERCHANTABILITY AND FITNESS FOR A PARTICULAR PURPOSE.

MPW is not liable for any damage to persons, property, or equipment, whether owned by a customer or third party, resulting from the use of an MPW service or from the presence of MPW equipment on or near premises.

RIGHT TO DENY SERVICE

All customers are required to maintain their property and water systems consistent with applicable building, safety, water, or other code standards. MPW reserves the right to deny service to any customer if the Utility determines that providing the utility service would create or perpetuate a hazardous, unsafe, or dangerous condition.

WATER MAIN EXTENSIONS, IMPROVEMENTS, & HYDRANTS

GENERAL

A water main may be extended provided there is reasonable expectation of future revenue being generated to justify the extension. All water main extensions will conform to the requirements of the Iowa Department of Natural Resources (IDNR), the City Code of Muscatine, Iowa, and these Service Rules.

Water main extensions shall be sized to meet minimum fire flow calculations.

Water mains may be enlarged when existing mains are insufficient in size to give adequate pressure and service to meet the demands of residential, commercial, or industrial customers.

All water main extensions shall comply with the Utility's "Standard Specifications for Water Supply Distribution System Improvements" as then currently filed with and approved by IDNR. Copies of the specifications are available for viewing at the MPW Business Office.

Any water main extension, enlargement, or water system improvement that is not provided for in these Service Rules may be referred to the Governing Body.

WATER MAIN EXTENSIONS

Main Extensions

Extension Approval

The decision to sell water to any customer outside the city limits rests solely with the Governing Body.

All approved water main extensions and other water services to customers outside the City limits shall comply with these Service Rules including all policies regarding water main extensions within the city limits

Extension Design

Water mains may be extended to new subdivisions or housing developments by contract between MPW and the developer. MPW shall review the developer's design in accordance with the "Standard Specifications for Water Supply Distribution System Improvements." The pipe sizes of the main extension shall be predicated on the anticipated demand for the development for the next 25 years including fire protection.

Developer Responsibilities

The developer must hire a contractor to provide materials and labor to install the extension to the design specifications of the Utility. After construction, the contractor must pressure test the installation and flush the installation or hire MPW to complete these tasks.

MPW will complete the bacteria tests at no expense to the contractor.

Extension Inspection

The developer must pay the Utility's expenses for a full-time inspector who must be present during construction to ensure compliance with the Utility's standard specifications.

Mains Larger than Required

The Utility may determine water mains larger than those required to serve the developer should be installed for future system requirements. In this case, the Utility will pay the incremental cost of the materials.

Final Ownership and Responsibility

Final ownership and responsibility for operation and maintenance of the water main extension rests with the Utility unless stipulated otherwise in the Water Main Extension Agreement.

Special Assessment

Water mains may be extended by "Special Assessment," if the City of Muscatine determines a water main extension is required in the public interest, and so declares as set forth in Section 384.42 of the Code of Iowa.

- In such a case, the City and Utility enter into a water main extension agreement substantially in accordance with the applicable Service Rules.
- The cost of said extension shall be assessed by the City to the property owners that are benefited, and the City will remit payment for the project to MPW.

HYDRANTS

Installation

MPW installs fire hydrants as follows:

- On water main extensions as provided in these Service Rules.
- On existing water mains in developed areas where existing hydrants are separated by more than 500'.
- Hydrants may not have any obstacles within 4' of the hydrant to maintain emergency operation.

Relocation

Fire hydrants may be relocated by the Utility when it is deemed in the public interest.

If a customer requests a hydrant relocated for their own benefit, the hydrant may be relocated, but the customer is responsible for all costs associated with the move. MPW must approve the new location. The Utility may require an advance deposit for the relocation.

Removal

Fire hydrants may be removed when their need is no longer demonstrated.

Installation Outside City Limits

Hydrants may be installed outside City limits only with the approval of the Governing Body.

Hydrant Usage

Fires

Fire hydrants are primarily used for fighting fires; therefore, operation is restricted to Fire Department and Utility personnel.

The following exceptions may be granted at the discretion of the Utility:

Construction

MPW may grant a contractor permission for construction purposes only, if no other source of water is available.

The contractor must contact MPW for the application. If granted permission, the necessary fitting, with backflow preventer valve, wrench, and operating instructions will be provided. Upon the return of the items to MPW, the contractor will be billed at the appropriate rate. MPW reserves the right to require a deposit for the fitting with backflow preventer, valve, wrench, and water usage.

The contractor is responsible for parts and labor required in the repair of a hydrant damaged due to contractor negligence.

Towboats

Towboats on the Mississippi River may have water service (via fire hydrant) as long as MPW has the personnel available to provide the service.

If the Utility provides the service, the towboat company will be billed for all costs.

Street Department and Waste Water Treatment Plant

MPW will designate those hydrants available to the City of Muscatine Street Department and Waste Water Treatment Plant. The designated list of hydrants may be obtained from MPW. The Utility reserves the right to alter or restrict the usage of these hydrants at any time.

Prohibited Usage of Fire Hydrants

- Filling of private swimming pools
- Irrigation
- Washing sidewalks, driveways and parking lots
- Any other usage that the Utility deems not appropriate

CUSTOMER RELATIONS

APPLICATION FOR SERVICE

Residential customers may obtain MPW services by visiting the MPW Business Office at 3205 Cedar Street, by calling 563-263-2631, or by visiting www.mpw.org. Commercial and Industrial customers may obtain service by visiting the MPW Business Office.

In order for the application to be complete, the applicant must provide:

- Full name of account holder, first and last name of other occupants
- Personally identifying information to verify identity
- Phone number(s)
- Previous address(es)
- Employer and employer telephone number
- Name, address, and telephone number of an Emergency Contact
- Collection of other customer information as required

The application process shall include:

- Payment of past due bills owed the Utility.
- Determination and collection of deposit, if applicable.
- Applicant's voluntary designation of a person or agency to receive a copy of any notice to disconnect service due to the applicant's nonpayment of a bill or deposit.
- An opportunity to enter into Budget Billing. This application may require other needed information.
- An opportunity to sign up for Automatic Payment. This application may require other needed information.
- Information about online account access.

As soon as practical after the approval of an application, the Utility will supply service to the applicant in accordance with these Service Rules and at a rate established by the Utility for the applicant's appropriate class of service.

Premises receiving service must also comply with equipment provisions of the *Service* section of these Service Rules.

Water Services are available to customers who are 18 years of age or older, or head of household.

The benefits of and/or rights conferred upon the customer by MPW are non-transferable, except when approved in writing by MPW.

When an account is established, MPW follows standard account verification procedures for security.

DEPOSITS

A deposit is intended to guarantee partial payment of bills for utility services. A deposit may be required prior to approval of the service application. A person other than the customer may pay the deposit. In any case where a deposit has been refunded or is found to be inadequate, a new or additional deposit may be required upon 12 days' written notice to the customer.

Credit Criteria for Initial Service Deposits

A deposit may be required of an applicant if any of the following criteria exists:

- Past payment history with MPW is unsatisfactory.
- Applicant has no credit or unsatisfactory credit with another utility provider.
- New service is for a different rate classification than that for which the payment history was established.

Initial Service Deposits

An initial service deposit may be required for services from applicants who meet the credit criteria above. The amount of an initial service deposit will not exceed up to the 2 highest meter readings for service during the previous 12 months.

Credit Criteria for New or Additional Deposits

A 12-day written notice will be sent to a customer who is required to provide a new or additional deposit, if the initial service deposit has been refunded or is found to be inadequate. The amount of a new or additional deposit will not exceed up to the 2 highest meter readings for service during the previous 12 months.

A new or additional deposit may be required from customers who meet any of the following criteria:

- Customer has made two late payments, or received two Non-Sufficient Funds (NSF) check or Automated Clearing House (ACH) reject notices, or a combination of any two, in the previous 12 months. If the customer has had service less than 12 months, the number of NSF or ACH reject notices will be prorated.
- Diversion of services or fraud.

Deposit Calculation Criteria

A customer's deposit may not exceed up to the 2 highest monthly meter readings for the previous 12 months based on current rates. The highest meter reading in the previous 12 months may be adjusted for the following:

- Change in the number of persons serviced.
- Change in type of service.
- Installation or removal of water conservation measures.

Where the service connection was not previously metered, the maximum estimated charge shall be based on comparable existing service of the Utility.

Receipt for Deposit

Each deposit, replacement of deposit, or supplement of a deposit will be reflected on the bill for the account. The Utility shall keep the following records concerning the deposit:

- The name and address of each customer on behalf of whom the deposit was made.
- The amount and date of the deposit.
- Each transaction concerning the deposit.

A receipt may be obtained by filing a written claim at the MPW Business Office and by providing adequate personal identification.

Interest on Deposits

The interest rate on deposits with the Utility is based on the Utility's prior year short-term investment earnings rate. This rate shall be reviewed every January 1 and adjusted as needed. Interest accrues from the date of deposit to the date of refund or to the due date of any MPW service bill to which the deposit is applied. The refund date is the date on which the refund is forwarded to the depositor's last known address.

Deposit Refund

Refund for Prompt Payment

The deposit will be applied to the current balance after 12 consecutive months of prompt payment, which includes 11 timely payments and 1 automatically forgiven late payment. If a customer is not eligible to have their deposit credited after 12 months, their account will be re-reviewed every 12 months to determine refund eligibility. If it is necessary to collect a new or additional deposit as per the *Credit Criteria for New or Additional Deposits*, the deposit will be retained until the final billing for the account.

Refund for Termination of Service

Upon termination of service, the deposit, plus accrued interest (if any), less any unpaid bill for services, shall be credited to the account. Any excess deposit will be refunded to the account holder.

Unclaimed Deposits and Overpayments

A record of each unclaimed deposit or overpayment will be maintained for a period of 2 years from the date service is terminated. During that time, MPW shall make a reasonable effort to return the funds. Deposits or overpayments remaining unclaimed 1 year after termination of service will be transferred to the State of Iowa in accordance with Chapter 556, Code of Iowa.

BILLING INFORMATION

Monthly meter readings are taken on dates designated by the Utility. If a meter cannot be read, the customer is asked to supply the meter reading on a card supplied by MPW, or via phone or an online submission. An estimated reading will be used if a reading is not received from the customer. Estimated meter readings cannot be used for billing for more than 3 consecutive months. A MPW representative must read each meter at least once every 3 years if the customer has provided the meter readings during that time.

Customers are billed monthly according to the appropriate rate schedule for metered service received during the billing period.

MPW will only provide specific billing information to the customer or their designee.

Billing Form

MPW may show the following information on the bill, or advise the customer (on the bill) that the information can be obtained by contacting MPW:

- The actual or estimated meter readings at the beginning and end of the billing period.
- The date of the meter readings.
- The number and kind of units metered.
- The identification of the applicable rate schedule.

- The account balance brought forward and amount of each charge for rate-schedule-priced Utility service, sales tax, other charges, late payment or other charges and total amount currently due.
- The last date for timely payment shall be clearly shown and shall not be less than 20 days after the bill is rendered.
- A distinct marking to identify the type of meter reading.
- A distinct marking to identify a minimum bill, and/or facility charge, which may be provided for in the rate schedule for each service class and will apply to any billing period during which service remains connected.
- Any conversions from meter reading units to billing units, or any other calculations to determine billing units from recording or other devices or any other factors such as automatic adjustments and amount of sales tax adjustments used in determining the bill.

Bill Payment Terms

A bill is due and payable when rendered and is considered delinquent after 20 days from the time it is rendered. A bill is considered rendered by MPW when deposited in the U.S. mail with postage prepaid or when sent electronically to an email account that a Customer has provided to the Utility or when delivered by MPW to the last known address of the party responsible for payment. A late payment charge of 1.5% of the unpaid balance will be assessed on past-due accounts. Each account will be granted 1 forgiveness of a late payment charge in each calendar year. The customer will be informed of the use of this one-time forgiveness on their next bill.

Customers can pay bills by mail, telephone, direct payment at the MPW Business Office, direct deposit through a financial institution, or through MPW's online bill payment system.

Failure to receive a properly rendered bill does not entitle the customer to relief from late payment charges. In addition to this late payment charge, disconnection and reconnection charges may still apply.

Partial Payments

Unless otherwise designated by the customer, partial payments will be applied to the various Utility products or services utilized by the customer in accordance with Utility practices. The late payment charge shall apply only to the bill amount outstanding after the due date.

Returned Checks and ACH Rejects

A service charge is assessed to any customer whose check is returned unpaid or ACH payment is rejected by the financial institution on which it is drawn. The service charge shall be in addition to the late payment charge if the check or ACH is not made good prior to the delinquent date of the bill. If one or more checks are dishonored or ACH payments rejected within a 6-month period, MPW may require future payments by cash, cashier's check, or money order.

Budget Billing

MPW offers Budget Billing to all residential customers. This plan is designed to limit the volatility of a customer's bill and maintain reasonable account balances. Budget Billing

- is offered to each eligible customer when the customer initially requests service;
- is available to existing eligible customers upon request anytime during the calendar year; and,
- may be cancelled at any time upon request of the customer.

The Budget Billing amount is calculated at the time of entry into the plan. It will be recalculated at least annually, but can also be recalculated monthly, quarterly, when requested by the customer, or whenever

price, consumption, or a combination of factors results in a new estimate differing by 10 percent or more from that in use.

When the amount is recalculated, the account balance is divided by 12, and the resulting Budget Billing amount is adjusted.

Irrespective of the account balance, a delinquency in payment shall be subject to the same collection and disconnection procedures as other accounts, with the late payment charge applied to the Budget Billing amount. MPW may terminate Budget Billing after 30 days of delinquency. Balances are addressed as follows:

- Any the balance due shall be paid at the time of termination.
- If there is a credit balance, the customer shall be allowed the option of obtaining a refund (if over \$25) or applying the credit to future charges.

The Utility is not required to offer a new Budget Billing plan to a customer for 6 months after the customer has discontinued Budget Billing.

Payment Agreements – Residential Customers

Availability of a Payment Agreement

A reasonable payment agreement may be offered to a customer in the following situations:

- Customer cannot pay a delinquent MPW bill in full, or
- Customer has an outstanding debt to MPW, and
- Customer is not in default of a payment agreement with MPW.

Reasonableness

A payment agreement is determined to be reasonable by considering the following:

- Current household income
- Ability to pay
- Payment history (including prior defaults on similar agreements)
- Size of the bill
- Amount of time and reason why the bill is outstanding
- Any special circumstances creating extreme financial hardship

The Utility may require the customer to confirm financial difficulty with an acknowledgment from the Iowa Department of Human Services or another agency.

Types and Terms of Payment Agreements

Payment Agreement

An agreement may be offered as follows:

Disconnection Length	Additional Conditions	Payment Agreement Terms
Received disconnection notice, or have been disconnected	Not currently in default of a payment agreement	Payments may be spread evenly over 3 months. Payments are set for specific amounts to be paid at specific times.

Payment Agreement Contents

The agreement will include the following:

- Terms and agreements of the payment agreement.
- Provisions for paying the current amount due.
- The address and a toll-free or collect telephone number where a qualified representative can be reached.

The document will be considered rendered to the customer when addressed to the customer's last-known address and deposited in the U.S. mail with postage prepaid. If delivery is not by U.S. mail, the document shall be considered rendered to the customer when delivered to the last-known physical or email address of the person responsible for payment for the service.

Each customer entering into a payment agreement will be granted at least 1 late payment that is made 4 days or less beyond the due date for payment and the payment agreement shall remain in effect.

Entering into a Payment Agreement

Agreements may be made over the phone or in person. In either instance, MPW will provide to the customer (within 3 days of the agreement date) a written document reflecting the terms and conditions of the payment agreement.

- For agreements made in person, the customer will receive a signed copy of the agreement.
- For agreements made over the phone, the customer will receive a copy in the mail (or other delivery method).

Unless the customer notifies MPW within 10 days from the date the document is rendered, the customer confirms acceptance of the terms of the agreement by making the first agreed-to payment.

Refusal of Payment Agreement by MPW

A customer may propose a payment agreement to MPW. If an agreement is not reached between MPW and the customer, MPW may refuse the offer orally, but the Utility must provide a written refusal to the customer (including the reason for the refusal) within 3 days of the oral notification. The written refusal shall be considered rendered to the customer when addressed to the customer's last-known address and deposited in the U.S. mail with postage prepaid. If delivery is by other than U.S. mail, the written refusal shall be considered rendered to the customer when handed to the customer or when delivered to the last-known address of the person responsible for the payment for the service.

Adjustment of Bills after Issuance (Meter Error)

Bills may be adjusted for the following reasons:

Meter Error

- Meter test has an average error of more than ± 2.0 % weighted average.
- Meter failure, which results in the meter failing to register the amount of water supplied during any period.

No Meter Error

- Incorrect reading of the meter.

- Incorrect application of the rate schedule.
- Incorrect connection of the metering installation.
- Other similar reasons.

Rules for adjustments due to metering or billing errors shall be in accordance with current MPW policy and practice.

DISCONNECTIONS, DENIALS, AND RECONNECTIONS

Customer Initiated (Voluntary)

Temporary Disconnections and Reconections – Meter (Voluntary)

Upon reasonable notice by a customer, MPW may make temporary disconnections for the customer's convenience. The customer may be required to pay a charge for disconnection and for reconnection. The customer will be advised of the charges at the time of the request.

Permanent Disconnections (Voluntary)

A customer requesting permanent disconnection shall provide a minimum 1 business day's notice to MPW. With proper notification, no charges shall be made for permanent disconnections.

Utility Initiated (Involuntary)

Just Cause for Disconnection or Denial (Involuntary – Other than Nonpayment)

MPW reserves the right to refuse or disconnect service for any of the reasons listed below, subject to the provisions of this section and other provisions of these Service Rules. If a customer fails to comply with a rule of the Utility, a 12-day written notice will be given, allowing the customer time to comply with the Service Rules. Except for reasons given in the first 4 items below or disconnection at the customer's request, no service will be disconnected unless the Utility is prepared to reconnect the service within 24 hours. A reconnection charge is posted to the account when the disconnection results from an act or omission on the part of the customer.

One written notice, including all reasons for the notice, will be given where more than one cause exists for disconnection of service. In determining the final date by which the account is to be settled or other specific action taken, the days of notice for the causes shall be concurrent.

Reasons for refusal or disconnection without notice are:

- Existence of a hazardous condition, as determined by MPW.
- Customer use of equipment in such a manner that will adversely affect MPW's equipment or service to others.
- Tampering with MPW-furnished/owned equipment. (For the purposes of these Service Rules, a broken or absent meter seal alone does not constitute tampering).
- Unauthorized use or resale of the Utility's service.

Reasons for refusal or disconnection with notice are:

- Violation of or noncompliance with these Service Rules.
- Failure of the customer or prospective customer to furnish service equipment, permits, certifications, or rights-of-way specified by the Utility as a condition of receiving service.
- Failure of the customer or prospective customer to fulfill his contractual obligations for service or facilities.

- Failure of the customer or prospective customer to permit the Utility safe and reasonable access to its equipment.
- Condition of the service creates a hazard to the distribution system.

Disconnection and Reconnection Fee (Involuntary – Other Than Nonpayment)

For any disconnection or reconnection pursuant to these Service Rules, the customer shall pay the current Utility applicable rates for labor, equipment, and materials.

Utility Initiated (Involuntary – Due to Nonpayment)

MPW reserves the right to refuse or disconnect service for nonpayment of the bill or deposit, subject to the provisions of these Service Rules.

MPW may disconnect service after 24-hour notice (and without a 12-day written notice) for failure of the customer to comply with the terms of a payment agreement.

Written Notice

MPW shall give a 12-day written notice to the customer and, where applicable, the person or agency designated by the customer to receive such notice, that service will be disconnected if the account is not settled. Notice shall include a collect telephone number where a representative qualified to provide additional information about the disconnection can be reached. Each Utility representative shall provide their first name to the caller and have immediate access to current, detailed information concerning the customer's account and previous contacts with MPW.

Multi-Occupancy Premises

If the disconnection will affect occupants of residential units leased from the customer (renters), the premises of any building known by the utility to contain residential units affected by disconnection must be posted, at least 2 days prior to disconnection, with a notice informing any occupants of the date when service will be disconnected and the reasons for disconnection.

Landlord Notification

In the cases of a residential customer, if attempted contact is unsuccessful, and MPW has reason to believe that the residential customer is a renter, the landlord, if known, shall be contacted to determine if the customer is still in occupancy, and if not, his present location. The landlord shall also be informed of the date when services may be disconnected.

Avoiding Disconnection – Disputed Bill

If the customer has received notice of disconnection (either 12-day or 24-hour) and has a dispute concerning a bill for Water Utility service, the customer may dispute their bill by notifying MPW of the reason for the dispute. The customer must pay the undisputed part of the bill. MPW will not disconnect water service for 45 days from the date the bill was mailed while the dispute is being resolved between the customer and MPW.

Disconnection

Disconnection of a residential customer will take place between the hours of 6 AM and 2 PM on a weekday and not on weekends or holidays.

Personal Contact

When disconnecting service to a customer, MPW shall make a diligent attempt to contact, by telephone or in person, the individual or agency responsible for paying the bill to inform the customer of the pending disconnection and available remedies.

If the attempt at customer contact fails, the premises will be posted with a notice informing the customer of the pending disconnection. The notice shall be posted at least 24 hours prior to disconnection. A posting charge is assessed to all accounts requiring a posting notice. The posting charge is reviewed periodically and adjusted as needed.

Reconnection

If a disconnected customer makes payment or other arrangements during the business hours of Monday – Friday, 8 AM to 3 PM, all reasonable efforts will be made to reconnect the customer that day. Before reconnection, all bills must be paid or the customer shall make satisfactory payment arrangements.

Reconnection Charge for Nonpayment

For any reconnection of service pursuant to these Service Rules, there is a reconnection service charge during normal working hours.

Additional charges apply for reconnection of service outside normal working hours. Reconnection charges are reviewed periodically by the Utility and adjusted as needed.

Abnormal Water Consumption

A customer who is subject to disconnection for nonpayment of bill and who has water consumption which appears to the customer to be abnormally high, may ask for assistance from MPW to identify the factors contributing to this usage pattern and to suggest remedial measures. MPW will provide assistance by discussing patterns of water usage that may be readily identifiable, suggesting that a usage audit be conducted, and identifying sources of water conservation information and financial assistance that may be available to the customer.

Insufficient Reasons for Denying Service

The following do not constitute sufficient cause for refusal of service to a present or prospective customer:

- Delinquency in payment for service by a previous occupant of the premises to be served.
- Delinquency in payment for service by an occupant if the customer applying for service is creditworthy and able to satisfy any deposit requirements.

CHARGES FOR SERVICES

Charged Services

Customers may be billed for the cost of services that are not MPW's responsibility, including the following:

- All laboratory services will be billed at the applicable rates for labor and materials.
- All bulk water purchases must be made at the MPW Business Office.
- Service tap fees as applicable.

Non-charged Services

The customer will not be billed for services or equipment for which MPW is responsible.

Underground Facilities Locating

The Utility will locate underground service facilities without charge. Customers should call Iowa One Call (811 or 1-800-292-8989) no less than 48 hours in advance of beginning work. Every effort to locate the underground facilities correctly will be made by MPW, but the Utility cannot guarantee its location nor be held liable. MPW will not locate private services as a practice, but will provide locates to customers as a courtesy, provided the customer waives any responsibility or liability to the Utility for any damages incurred since the Utility cannot guarantee the accuracy of the locations.

CUSTOMER COMMUNICATIONS

Utility Customer Representative

A Utility representative charged with customer communication must give their first name to the customer, whether communication is in person or by telephone. The representative must have immediate access to current detailed information concerning the customer's account and previous contact with the Utility and shall be properly qualified and instructed in the screening and prompt handling of complaints.

Telephone Procedure

Telephone number 563-263-2631 is attended continuously 24 hours a day, 7 days a week for the handling of problems or complaints of an emergency nature. It is staffed during business hours Monday through Friday to handle routine business questions and other communications.

Complaint Procedure

Customers should contact an MPW Customer Service Representative to initiate a complaint. The complaint may be pursued with the appropriate Supervisor, Manager, Director, and the General Manager, in that order, if the customer is not satisfied with the initial handling of the complaint.

Complaints concerning the charges, practices, facilities, or services of the Utility will be investigated promptly, thoroughly, and courteously. MPW keeps records of written complaints sufficient to enable review and analysis of its procedures and actions. Based on MPW staff judgment, customers may be asked to submit complaints in writing. The complaint should include the following information:

- Name(s) of complainant
- Address(es) of complainant
- Telephone number(s) of complainant
- Nature of the complaint
- Relief sought

A written complaint may be filed with the Chairperson of the Governing Body if the customer is not satisfied with the General Manager's handling of the complaint. If the Chairperson believes the customer's complaint warrants further attention, the Chairperson may place the complaint on the agenda of the next regularly scheduled Board meeting for the ultimate resolution of the complaint by the Governing Body.

A customer who is unable to travel need not appear before any Utility official described above in person to explain the nature of their complaint. They may do so by telephone or in some other mutually agreeable fashion.

CUSTOMER OBLIGATIONS

Acceptance of any Utility service obligates a customer to all conditions of service set forth by the Utility, and these Service Rules. Customers may request a copy of the Service Rules by contacting MPW Customer Service Representatives at 3205 Cedar St., Muscatine, IA, by calling 563-263-2631, or by viewing the Service Rules on www.mpw.org. The Utility reserves the right to revise the Service Rules and conditions of service at any time.

Use of the Utility's Facilities by Customers and Others

Utility Facilities

The customer or any third party shall not, without written consent from MPW, use any of the hydrants, structures, or other Utility facilities for fastening thereto, support, or for any other purpose whatsoever. Nor shall the customer or a third party locate anything in such proximity to the Utility's facilities that will cause, or be likely to cause, interference with service or a dangerous condition in connection with unauthorized use of hydrants.

Non-liability of the Utility

The Utility assumes no liability for unauthorized attachments, equipment, or appurtenances whether attached by individuals or companies. Upon becoming aware of such attachments, MPW will remove them immediately. In the case Utility personnel become aware of illegally attached pipes, equipment, or appurtenances that are of a hazardous nature to life, limb or property, such attachments will be removed immediately by the Utility without notification

Customer Liability for Damages or Alterations

Customer Liability

The customer is responsible for all damage to, or loss of, Utility property located on customer's premises unless the damage or loss is due to the negligence of the Utility or by any act or omission on the part of the Utility or its authorized representative.

Protection of Utility's Facilities on Customer's Premises

All equipment installed by the Utility at its own expense is the Utility's facilities. Customers are responsible to protect the Utility's facilities on the customer's premises and not interfere with or alter or permit interference with or alteration of the Utility facilities except by duly authorized MPW representatives.

Under no circumstances or conditions shall any person who is not a Utility representative connect to or disconnect from any meter or disturb any connections between the meter and the service after the meter has been installed. All water services must be connected or disconnected only by an authorized MPW representative. Any tampering constitutes theft of service and may lead to disconnection as outlined in the appropriate theft of utility services policies and procedures.

Customer Equipment

Customer Equipment Standards

Except for facilities defined in *Extent of Service*, the customer is responsible for all equipment on customer's premises. The installation and maintenance of customer facilities shall be consistent with applicable standards imposed by these divisions of the Service Rules dealing with special conditions of service, applicable engineering practices, and any other applicable statutory or administrative law.

Utility Not Liable

No inspection or approval by the Utility of a customer's compliance with the *Service* section shall be construed to impose any duty or liability on the Utility, but shall be considered solely for ensuring protection of MPW's property and for ensuring the continuity of service to MPW customers.

Home Water Filters

Information regarding in-home water filters is available at www.mpw.org.

ACCESS TO CUSTOMER PREMISES

Customer and owner authorize MPW, or its designees, to:

- Enter their home, business, or upon their property, in the presence of the customer or their representative, during normal business hours or by appointment, to install, inspect, test, maintain, replace, remove, or otherwise deal with MPW-supplied equipment and services
- Access the outside areas of the customer's property, at reasonable times even without the customer being present for these same purposes.

Customer acknowledges that emergencies and after hours call outs may necessitate access to premises beyond normal business hours.

Customer and owner also grant to MPW, without charge, right-of-way over and on the premises on which MPW-owned equipment and structures are located.

WATER EXHIBITS

Exhibit 1 Typical Residential Water Service and Meter Installations

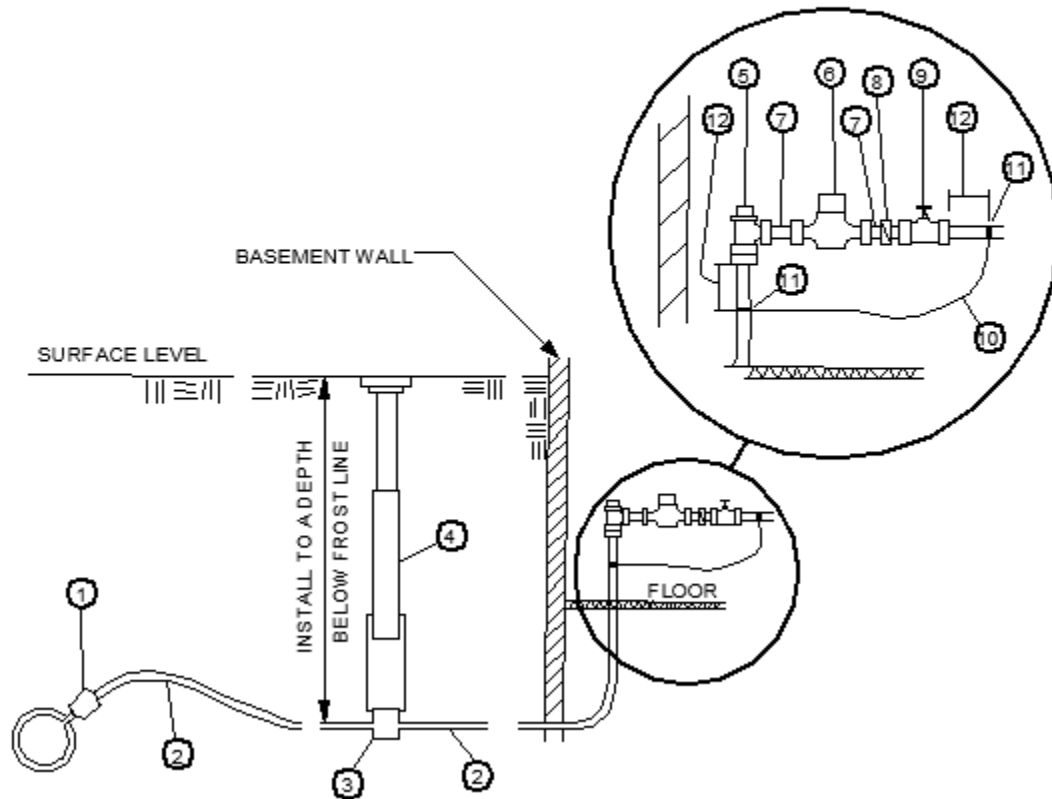

1. TAP CORPORATION VALVE: (FURNISHED AND INSTALLED BY MUSCATINE POWER AND WATER AT OWNER'S EXPENSE)
2. SERVICE LINE FROM TAP CORPORATION TO MAIN SERVICE VALVE: (BY OWNER)
NOTE A: TYPE K-COPPER, 1" MINIMUM OR LARGER ACCORDING TO WATER FLOW DEMANDS.
NOTE B: SERVICE LINE MAY ENTER RESIDENCE THROUGH THE FLOOR OR BASEMENT WALL
3. CURB VALVE: (BY OWNER) 1" MINIMUM. INSTALLED OUTSIDE OF BUILDING AND NEAR OWNER'S SIDE OF THE PROPERTY LINE
4. CURB VALVE RISER: (BY OWNER) TELESCOPING TYPE FACILITATING ADJUSTMENT TO SURFACE LEVELS TO AVOID TRIPPING HAZARDS
5. MAIN SERVICE VALVE: (BY OWNER) STRAIGHT OR ANGLE, EQUIPPED WITH A WHEEL OR LEVER TURN-OFF
6. METER: (FURNISHED AND SET BY MUSCATINE POWER AND WATER) INSTALLATIONS SHALL BE IN AN ACCESSIBLE PLACE, HAVING A CLEAR FRONTAL APPROACH WITH A MINIMUM OF FIVE FEET HEAD ROOM, A

- CLEAR WORKING AREA OF ONE FOOT ON EITHER SIDE OF THE METER CENTERLINE, A MINIMUM OF SIX INCHES FROM AN ADJACENT WALL TO THE NEAREST EDGE OF THE METER'S MAIN BODY, AND NO CLOSER THAN SIX INCHES OR MORE THAN THREE FEET FROM THE FLOOR
7. METER COUPLINGS WITH SWVEL NUTS: (FURNISHED BY MUSCATINE POWER AND WATER, INSTALLED BY THE OWNER)
 8. BACKFLOW PREVENTION PER MPW'S BACKFLOW PREVENTION POLICY
 9. BACK WATER VALVE: (BY OWNER) STRAIGHT OR ANGLED EQUIPPED WITH EITHER A WHEEL OR LEVER TURN-OFF
 10. LOOPEDED GROUNDING JUMPER CONDUCTOR: (BY OWNER) REQUIRED BY CITY ELECTRIC CODE. JUMPER CONDUCTOR SHALL HAVE A MINIMUM SIZE OF NO. 4 AWG BARE COPPER AND SUFFICIENT LENGTH TO PROVIDE A DISTANCE ONE FOOT FROM THE METER IN ANY DIRECTION
 11. BONDING CLAMPS: (BY OWNER) SHALL BE BLACKBURN TYPE BJ OR EQUIVALENT
 12. MINIMUM DISTANCE BETWEEN BONDING CLAMPS AND VALVE: THREE INCHES

* FURNISHED BY MPW
UPDATED: 3-11-14

Exhibit 1A Typical Residential HDPE Water Service and Meter Installations

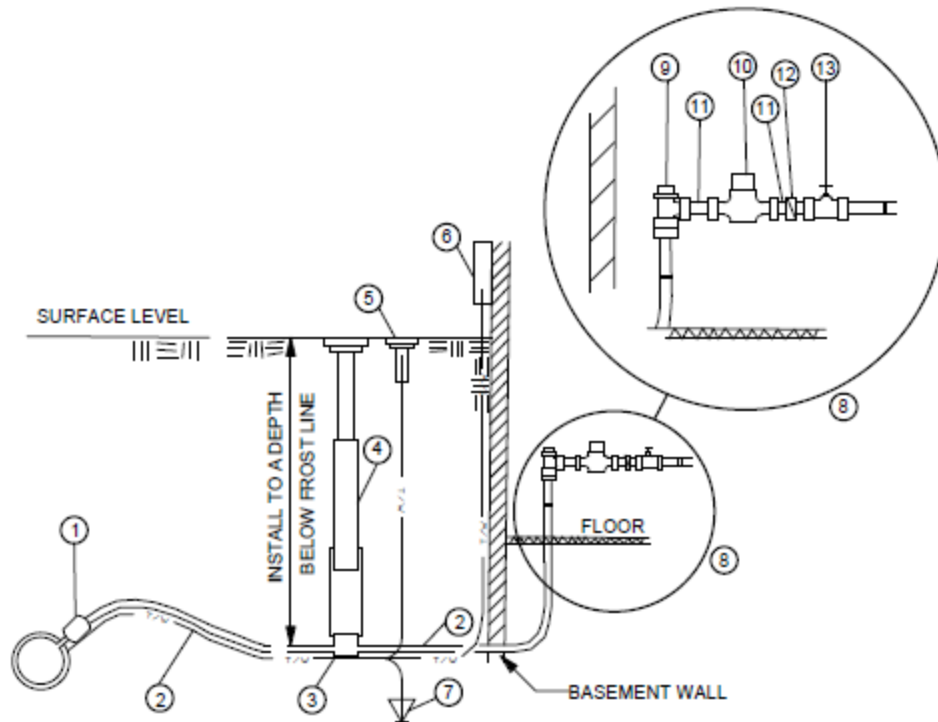

1. TAP CORPORATION VALVE: (FURNISHED AND INSTALLED BY MUSCATINE POWER AND WATER AT OWNER'S EXPENSE)
2. TYPE K COPPER OR DR11 HDPE, (BY OWNER) 1" DIAMETER MINIMUM OR LARGER ACCORDING TO WATER FLOWS. IF WATER MAIN IS DIP, PIPING FROM CORPORATION TAP TO CURB STOP MUST BE TYPE K COPPER. IF WATER MAIN IS HDPE, PIPING FROM CORPORATION TAP TO CURB STOP MAY BE HDPE SD11. INSTALLATION MUST INCLUDE TRACER WIRE. TRACER WIRE SHALL BE HIGH STRENGTH #12 COPPER HEAD BRAND WIRE WITH A 45MIL COATING. IF SERVICE LINE IS INSTALLED BY HDD, USE COPPER HEAD "SOLOSHOT" PART NUMBER 1245B-EHG. IF SERVICE IS INSTALLED BY OPEN TRENCH, USE COPPER HEAD "SUPERFLEX" PART NUMBER 1230B-3F.
3. CURB VALVE: (BY OWNER) 1" MINIMUM, INSTALLED OUTSIDE OF BUILDING AND NEAR OWNER'S SIDE OF THE PROPERTY LINE
4. CURB VALVE RISER: (BY OWNER) TELESCOPING TYPE FACILITATING ADJUSTMENT TO SURFACE LEVELS TO AVOID TRIPPING HAZARDS.
5. TRACER WIRE BOX: (BY OWNER) MUST USE COPPERHEAD BRAND "SNAKEPIT" MAGNETIZED TRACER BOX (PART NUMBER RB148TP IF BOX IS IN ROADWAY, USE LD148TP IF NOT IN ROADWAY) THIS INGROUND BOX SHALL BE DIRECTLY ADJACENT TO THE CURB STOP BOX.
6. TRACER WIRE TERMINATION ON STRUCTURE: (BY

- OWNER) MUST USE COPPER HEAD BRAND "COBRA TEST STATION" (PART NUMBER T1-875) PROPERLY SECURED TO THE STRUCTURE DIRECTLY ABOVE POINT WHERE SERVICE LINE ENTERS RESIDENCE TO TERMINATE TRACER WIRE.
7. ANODE: (BY OWNER) MUST USE COPPERHEAD BRAND "MAGNESIUM ANODE" (PART NUMBER ANO-100S). ANODE MUST BE PLACED AT END OF TRACER WIRE ADJACENT TO CURB STOP.
8. SERVICE LINE MAY ENTER RESIDENCE THROUGH THE FLOOR OR BASEMENT WALL.
9. MAIN SERVICE VALVE: (BY OWNER) STRAIGHT OR ANGLE, EQUIPPED WITH A WHEEL OR LEVER TURN-OFF
10. METER: (FURNISHED AND SET BY MUSCATINE POWER AND WATER) INSTALLATIONS SHALL BE IN AN ACCESSIBLE PLACE, HAVING A CLEAR FRONTAL APPROACH WITH A MINIMUM OF FIVE FEET HEAD ROOM, A CLEAR WORKING AREA OF ONE FOOT ON EITHER SIDE OF THE METER CENTERLINE, A MINIMUM OF SIX INCHES FROM AN ADJACENT WALL TO THE NEAREST EDGE OF THE METER'S MAIN BODY, AND NO CLOSER THAN SIX INCHES OR MORE THAN THREE FEET FROM THE FLOOR
11. METER COUPLINGS WITH SWIVEL NUTS: (FURNISHED BY MUSCATINE POWER AND WATER, INSTALLED BY THE OWNER)
12. BACKFLOW PREVENTION: (BY OWNER) PER MPW'S BACKFLOW PREVENTION POLICY
13. BACK WATER VALVE: (BY OWNER) STRAIGHT OR ANGLED EQUIPPED WITH EITHER A WHEEL OR LEVER TURN-OFF

* FURNISHED BY MPW
UPDATED: 3-14-16

Exhibit 2 Minimum Rectangular Vault Requirements for One 5/8-inch, 3/4-inch Or 1-inch Water Meter

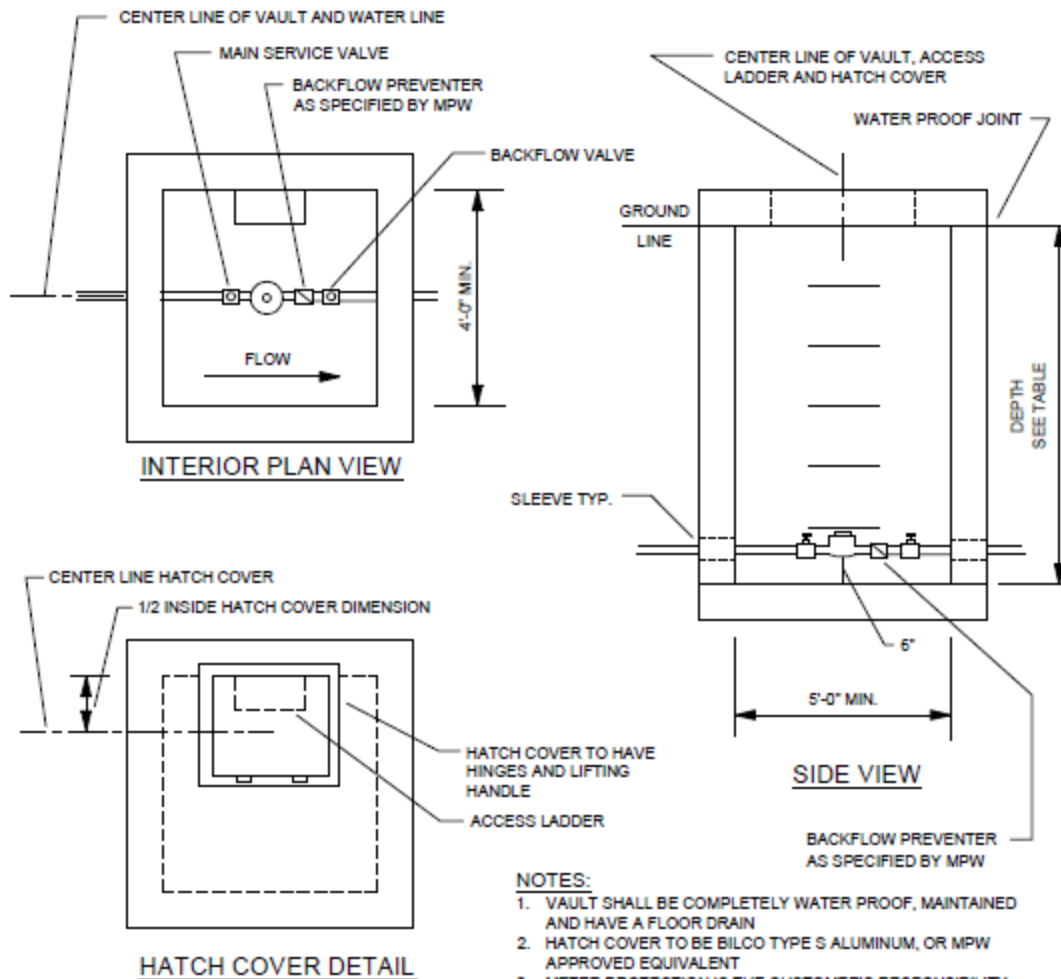

NOTES:

1. VAULT SHALL BE COMPLETELY WATER PROOF, MAINTAINED AND HAVE A FLOOR DRAIN
2. HATCH COVER TO BE BILCO TYPE S ALUMINUM, OR MPW APPROVED EQUIVALENT
3. METER PROTECTION IS THE CUSTOMER'S RESPONSIBILITY AND IT MAY BE DESIRABLE TO PROVIDE A MEANS OF PADLOCKING THE HATCH
4. LADDER SHALL BE DESIGNED ACCORDING TO OSHA-GENERAL INDUSTRY STANDARDS (1910.27 FIXED LADDERS)
5. MAIN SERVICE LINE AND BYPASS LINE VALVE MUST BE OF TYPE AND DESIGN THAT CAN BE SEALED BY THE UTILITY
6. A SUPPORT MAY BE DESIRABLE FOR MAINTAINING MINIMUM FLOOR TO METER DISTANCES PROVIDING THAT THE SUPPORT IS NOT PERMANENTLY INSTALLED

* FURNISHED BY MPW
UPDATED: 8-9-07

Exhibit 3 Minimum Circular Vault Requirements for One 5/8-inch, 3/4-inch Or 1-inch Water Meter

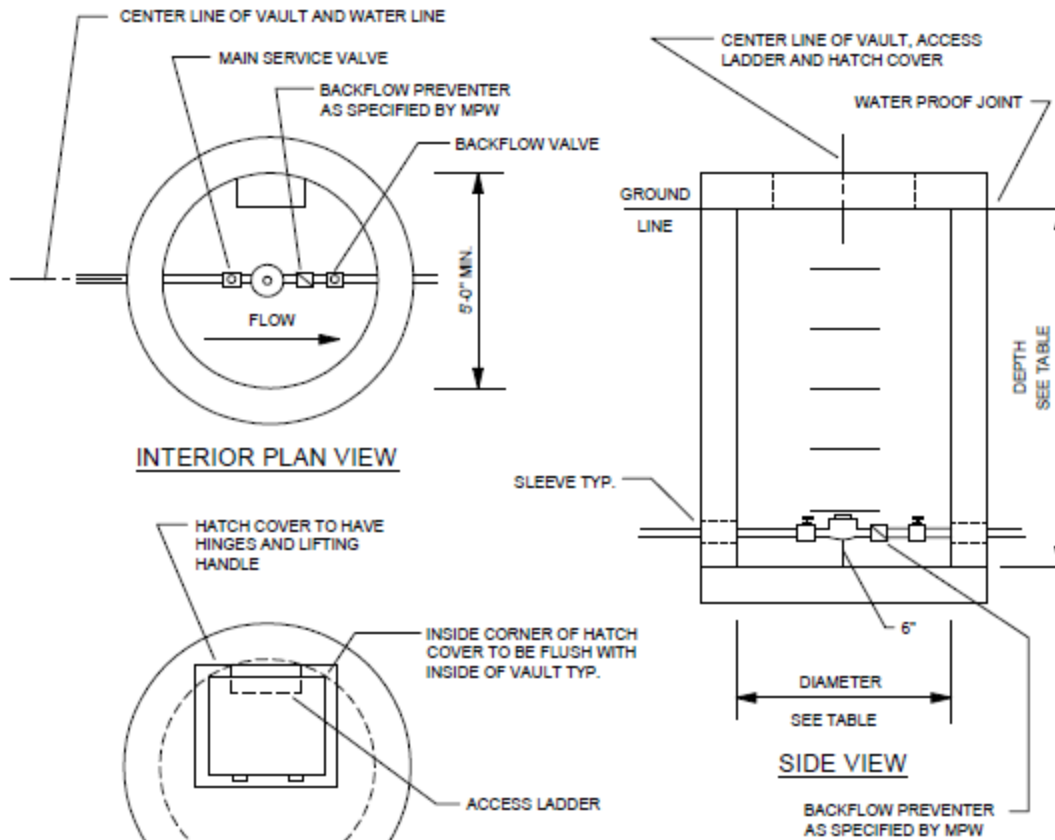

HATCH COVER DETAIL

VAULT SIZE TABLE

DIAMETER
5

NOTES:

1. VAULT SHALL BE COMPLETELY WATER PROOF, MAINTAINED AND HAVE A FLOOR DRAIN
2. HATCH COVER TO BE BILCO TYPE S ALUMINUM, OR MPW APPROVED EQUIVALENT
3. METER PROTECTION IS THE CUSTOMER'S RESPONSIBILITY AND IT MAY BE DESIRABLE TO PROVIDE A MEANS OF PADLOCKING THE HATCH
4. LADDER SHALL BE DESIGNED ACCORDING TO OSHA-GENERAL INDUSTRY STANDARDS (1910.27 FIXED LADDERS)
5. MAIN SERVICE LINE AND BYPASS LINE VALVE MUST BE OF TYPE AND DESIGN THAT CAN BE SEALED BY THE UTILITY
6. A SUPPORT MAY BE DESIRABLE FOR MAINTAINING MINIMUM FLOOR TO METER DISTANCES PROVIDING THAT THE SUPPORT IS NOT PERMANENTLY INSTALLED

* FURNISHED BY MPW
UPDATED: 8-9-07

Exhibit 4 Minimum Rectangular Vault Requirements for One 1 1/2-inch Or 2-inch Water Meter

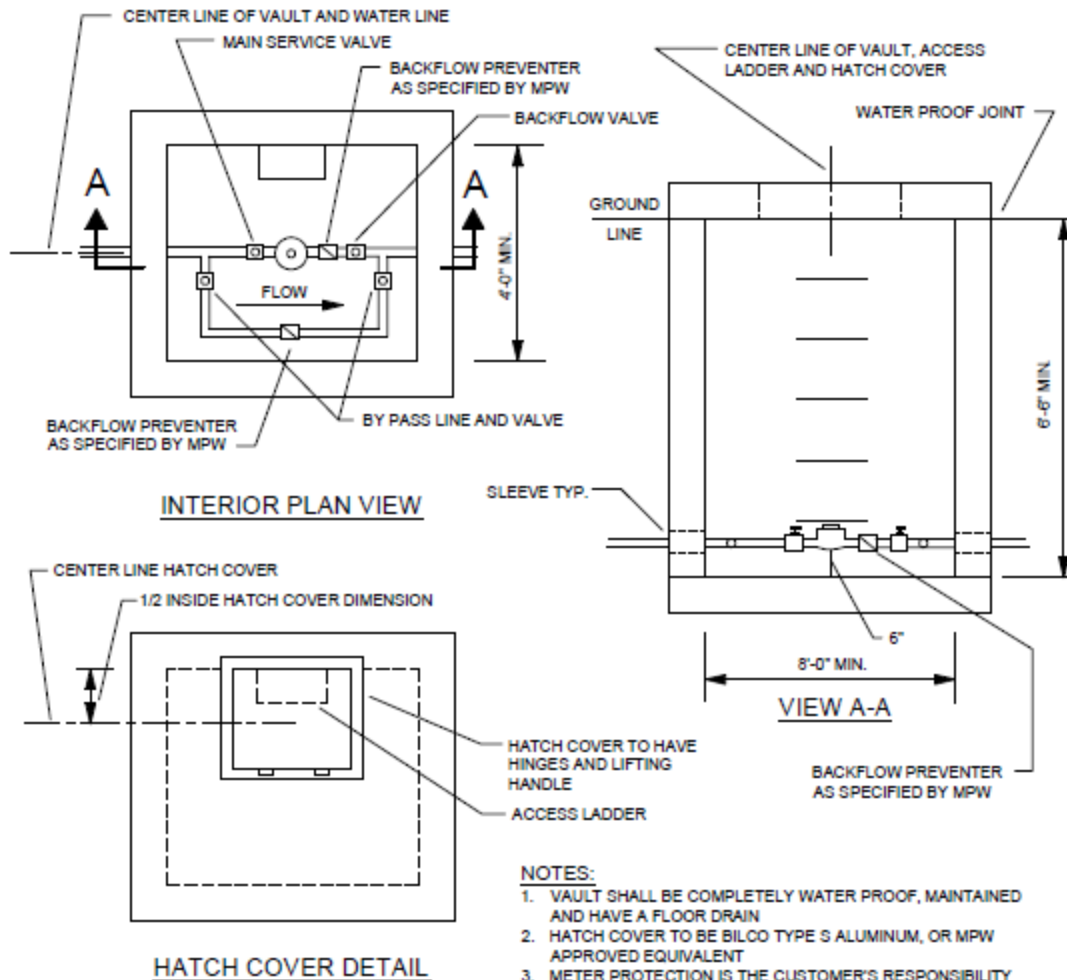

* FURNISHED BY MPW
UPDATED: 8-9-07

Exhibit 5 Minimum Circular Vault Requirements for One 1 1/2-inch Or 2-inch Water Meter

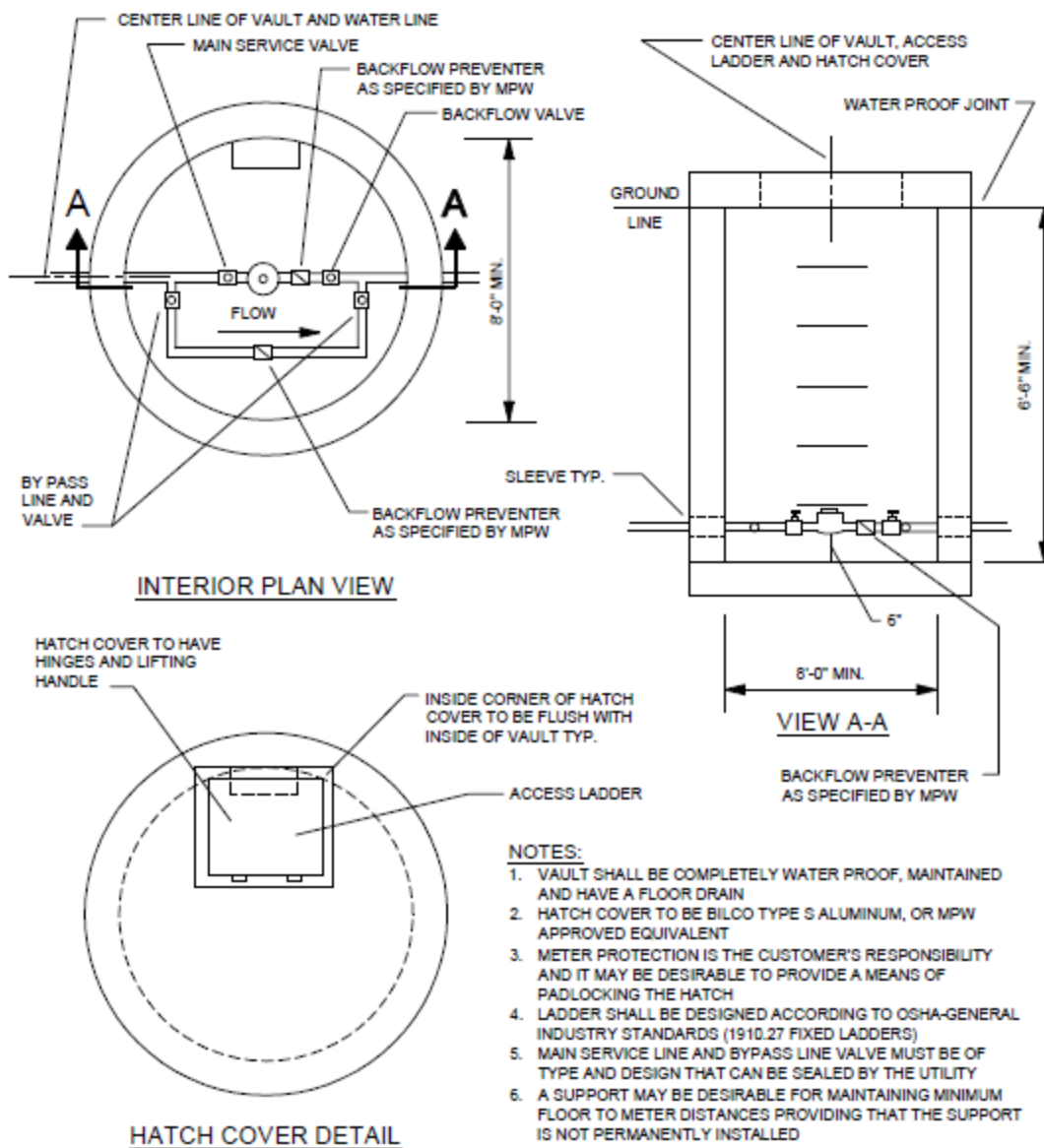

* FURNISHED BY MPW
UPDATED: 8-9-07

Exhibit 6 Minimum Rectangular Vault Requirements for Two 1 1/2-inch Or 2-inch Water Meters

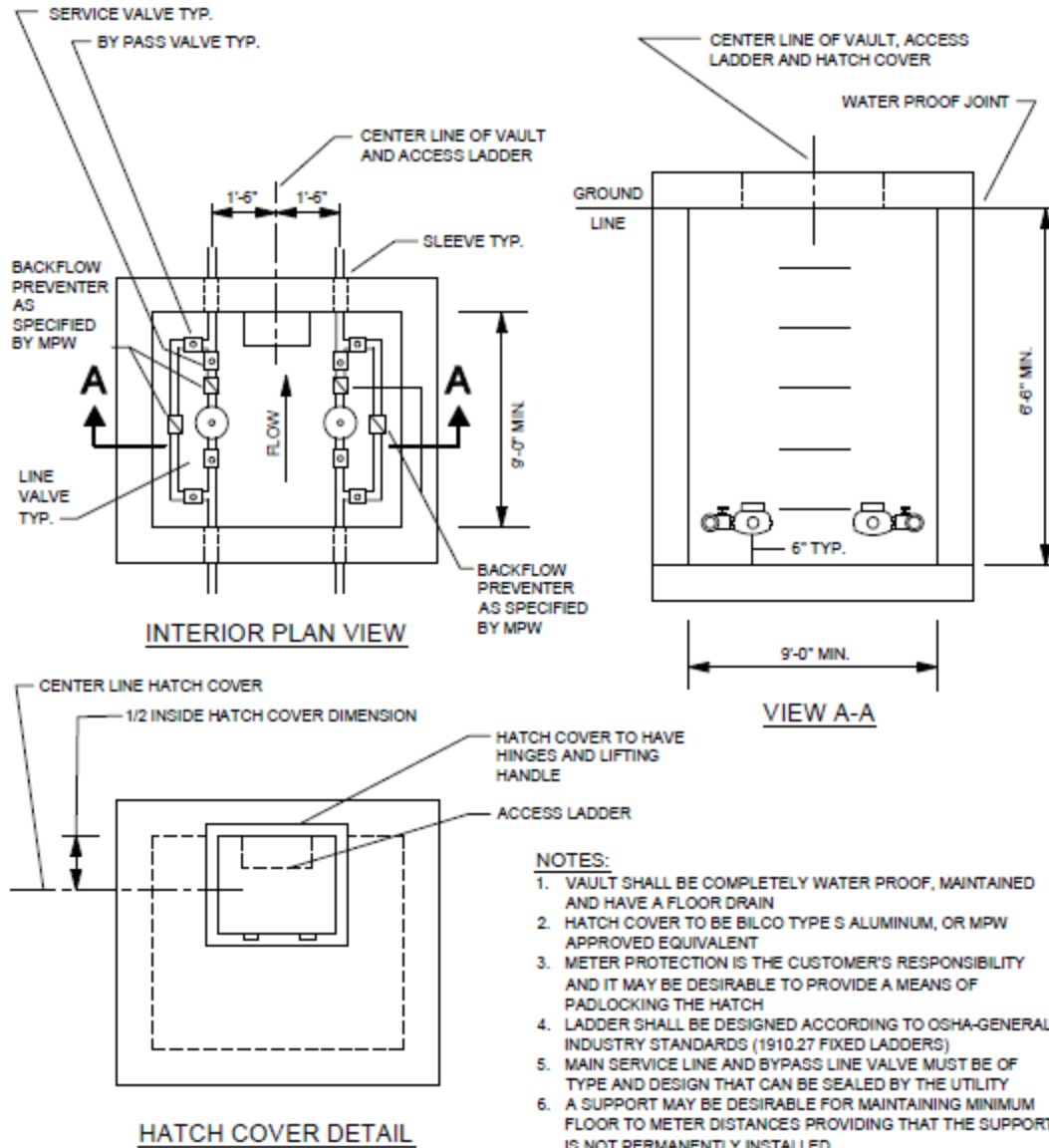

* FURNISHED BY MPW
UPDATED: 8-9-07

Exhibit 7 Minimum Circular Vault Requirements for Two 1 1/2-inch or 2-inch Water Meters

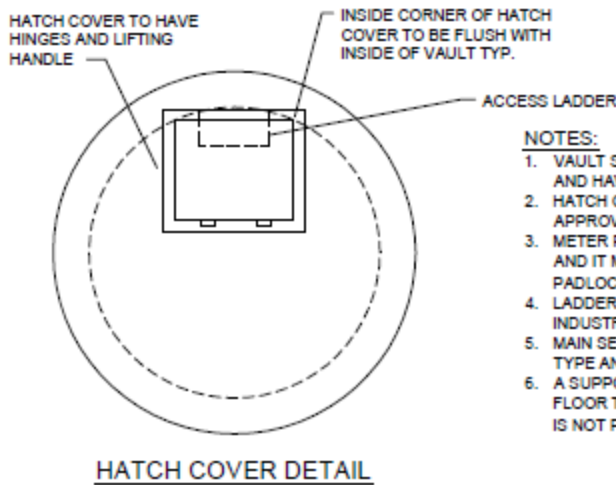
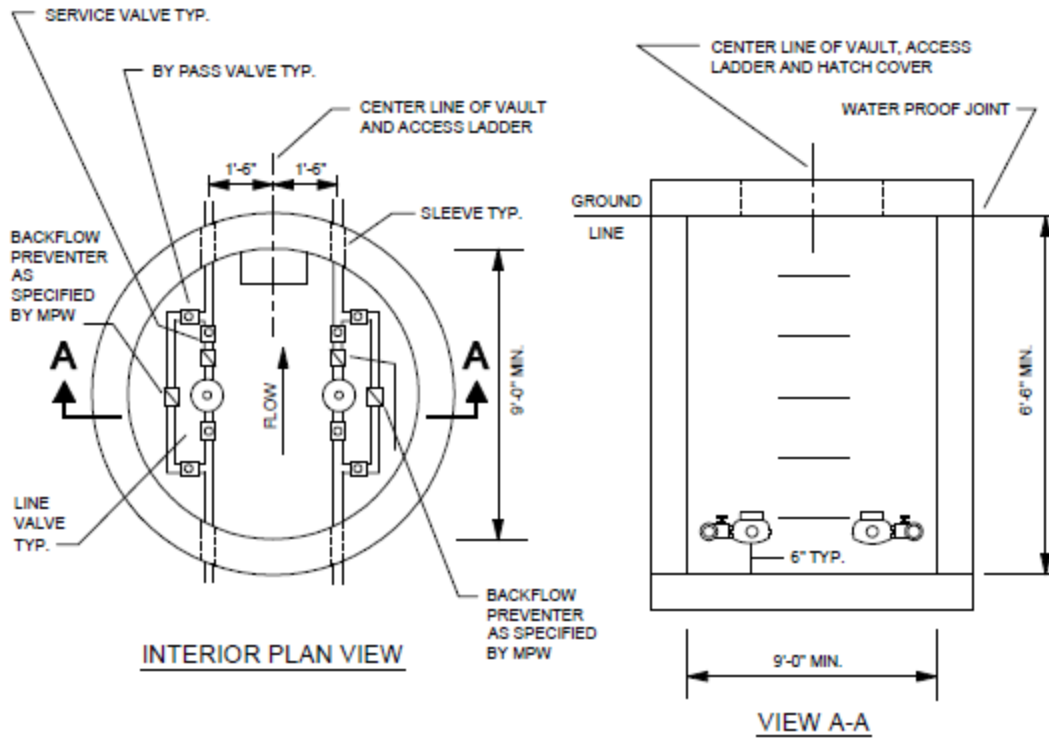

NOTES:

1. VAULT SHALL BE COMPLETELY WATER PROOF, MAINTAINED AND HAVE A FLOOR DRAIN
2. HATCH COVER TO BE BILCO TYPE S ALUMINUM, OR MPW APPROVED EQUIVALENT
3. METER PROTECTION IS THE CUSTOMER'S RESPONSIBILITY AND IT MAY BE DESIRABLE TO PROVIDE A MEANS OF PADLOCKING THE HATCH
4. LADDER SHALL BE DESIGNED ACCORDING TO OSHA-GENERAL INDUSTRY STANDARDS (1910.27 FIXED LADDERS)
5. MAIN SERVICE LINE AND BYPASS LINE VALVE MUST BE OF TYPE AND DESIGN THAT CAN BE SEALED BY THE UTILITY
6. A SUPPORT MAY BE DESIRABLE FOR MAINTAINING MINIMUM FLOOR TO METER DISTANCES PROVIDING THAT THE SUPPORT IS NOT PERMANENTLY INSTALLED

* FURNISHED BY MPW
UPDATED: 8-9-07

Exhibit 8 Turbo-Meter Installation Specifications

1. All turbo-meters shall have a manufacture recommended strainer upstream of the meter. The strainer's exact location will be determined by the meter manufacturer.
2. Backflow preventer may not be installed upstream of the meter.
3. Five diameters of straight pipe must be installed directly upstream of the strainer or meter.
4. Unweighted and weighted backflow preventer will be allowed no closer than 5 pipe diameters downstream from the downstream meter flange.
5. All usage outlet tees and elbows shall be installed downstream of the downstream by-pass tee.
6. By-pass valves will be sealed by the Utility in the closed position when not being used for meter maintenance.
7. Incorporation of a service saddle (or reducing tee) 2 pipe diameters or further downstream from the downstream meter flange will be required. Size will be determined according to the pipe diameter of the installation.
8. Meter testing outlet shall be extended to outside of vault or building cover. Terminated end will be equipped with a 2-1/2" fire hose adapter.

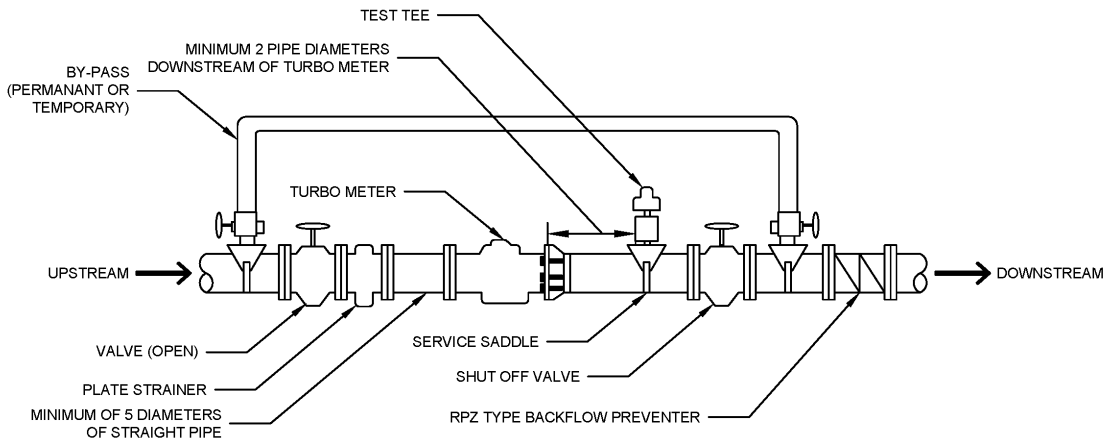

* FURNISHED BY MPW
UPDATED: 1-19-16

Exhibit 9 Minimum Rectangular Vault Requirements 3-inch to 12-inch Water Meters

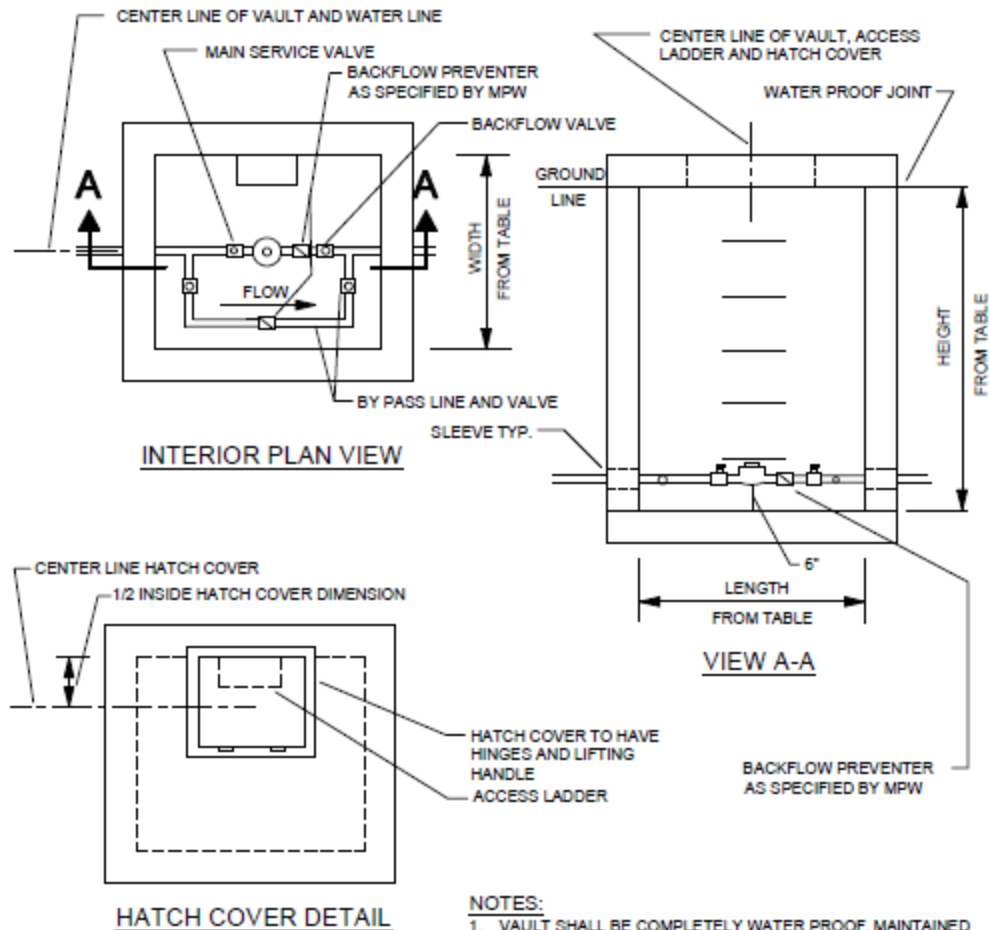

NOTES:

1. VAULT SHALL BE COMPLETELY WATER PROOF, MAINTAINED AND HAVE A FLOOR DRAIN
2. HATCH COVER TO BE BILCO TYPE S ALUMINUM, OR MPW APPROVED EQUIVALENT
3. METER PROTECTION IS THE CUSTOMER'S RESPONSIBILITY AND IT MAY BE DESIRABLE TO PROVIDE A MEANS OF PADLOCKING THE HATCH
4. LADDER SHALL BE DESIGNED ACCORDING TO OSHA-GENERAL INDUSTRY STANDARDS (1910.27 FIXED LADDERS)
5. MAIN SERVICE LINE AND BYPASS LINE VALVE MUST BE OF TYPE AND DESIGN THAT CAN BE SEALED BY THE UTILITY
6. A SUPPORT MAY BE DESIRABLE FOR MAINTAINING MINIMUM FLOOR TO METER DISTANCES PROVIDING THAT THE SUPPORT IS NOT PERMANENTLY INSTALLED

VAULT SIZE CHART

METER SIZE	WIDTH	LENGTH	HEIGHT
3"	6"	16"	6'-6"
4"	6"	17"	6'-6"
6"	6"	20"	6'-6"
8"	6"	21"	6'-6"
10"	6"	24"	6'-6"
12"	6"	24"	6'-6"

VAULT WIDTH FOR TANDEM METERS WILL DOUBLE THE AMOUNT IN THE ABOVE CHART.

* FURNISHED BY MPW
UPDATED: 8-9-07